

ERTL PEDAL TRACTOR

ASSEMBLY INSTRUCTIONS



TOMY®

Your pedal tractor's durable construction offers your child years of enjoyment when properly assembled and maintained. Please read all instructions carefully prior to beginning assembly and keep this instruction manual on file for future reference.

3+



WARNING:

ADULT ASSEMBLY IS REQUIRED

To reduce the risk of injury, keep small parts out of reach of children. This product requires assembly by an adult prior to use. This product should at all times, be used by the child under direct supervision of an adult and should not be used on or near roads, steps, stairways, hills or pool areas. Children should wear shoes.

DO NOT ALLOW MORE THAN ONE CHILD TO RIDE AT A TIME.

TOOLS REQUIRED:

- Wrench in the package, M6, M5
- Medium Phillips and straight screwdrivers
- Pliers or vise grips
- Crescent wrench or open end metric wrenches
- Hammer
- Oil
- Block of wood
- Capnut driver in the package

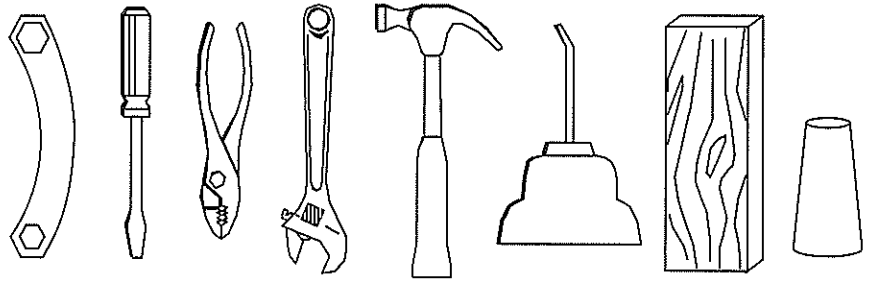

FAMILIARIZE YOURSELF WITH THIS HARDWARE:

(23) M5 x 75 Screw
1 Each

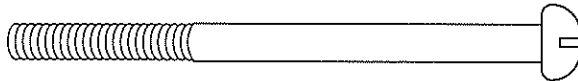

(24) M5 x 31 Screw
1 Each

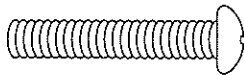

(25) M5 x 12 Screw
4 Each

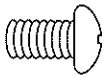

(26) M6 x 15 Bolt
6 Each

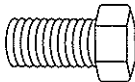

(27) M5 x 38 Screw
1 Each

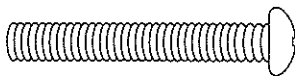

(28) M4 x 6 Screw
7 Each



(29) ø4 x 20 T/Screw
2 Each

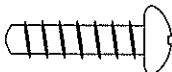

(30) ø19 OD x ø 11.8 ID Washer
4 Each

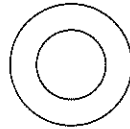

(31) ø24 OD x ø13 ID Washer
4 Each

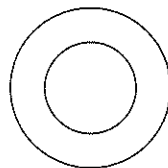

(32) ø14 OD x ø4 ID Washer
2 Each

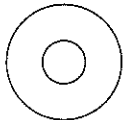

(33) Cotter Key
2 Each



(34) Tooth Washer Nut M6
6 Each



(35) Tooth Washer Nut M5
6 Each



(36) Square Nut M5
1 Each



(37) Capnut 11mm
8 Each

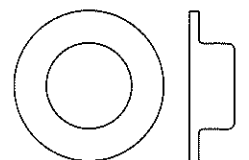

STEP 1

In order to protect your flooring or carpet from damage or stains it is suggested that you assemble your tractor-cycle in the lid of the shipping carton. To begin assembly, lay the tractor body on its side over one wall of carton lid, as shown. Place steering wheel on steering shaft. Align hole in steering shaft with those in steering wheel and insert M5 x 31 screw through holes. Thread tooth washer nut M5 onto screw and tighten. Place seat into the desired position on seat base of tractor body, (this can be further adjusted to suit child after final assembly). Align holes in seat with desired hole in body and tap the M5 x 75 screw through the holes with a hammer. Thread tooth washer nut M5 on and tighten.

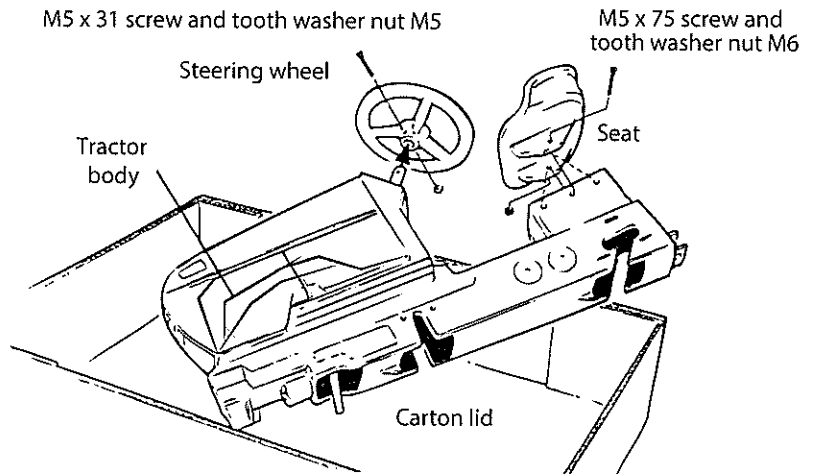

STEP 2

A Assemble pedals to pedal crank arm. Slip $\phi 19$ OD x 11.8 ID washer onto one end of pedal crank. Slip pedal onto crank with circular recess at top. Place capnut into position and proceed to Subassembly B.

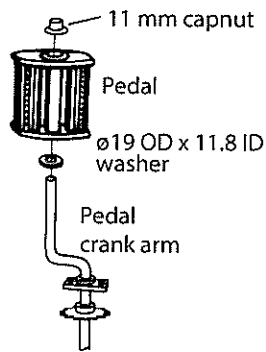

B Place pedal crank over edge of workbench or table, as shown. Using the capnut driver supplied, hammer capnut onto end of pedal crank. Repeat Subassemblies A and B.

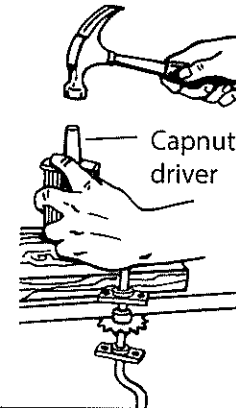

STEP 3

Turn tractor over in carton lid so that it rests on seat and steering wheel. Remove chain from its protective carton, (careful, it's a bit greasy), drape chain over assembled pedal crank arm as shown, and feed chain through "chain tunnel" of body toward rear of tractor, finally resting pedal crank arm in pedal slot. Reaching into rear chain access hole of body, lift end of chain out of body. Pass rear axle through loop of chain; squared end of rear axle shaft must be on left side of tractor when upside down, (see illustration). Place rear axle in rear axle slot of body. Use special included wrench to hold kepnuts for assembly of pedal arm and rear hubs. Pass M5 x 12 screws through body and pedal bearing backing plate, trapping pedal bearing into cupped recess in body; thread tooth washer nut M5 onto bolts and tighten. Slide assembled axle housing (from Subassembly Step 2) over one end of axle. One at a time, pass M6 x 15 bolts through holes in housing and body, (this is easier with housing in full forward position). Thread nuts onto bolts - DO NOT TIGHTEN. Repeat this assembly for other side. To adjust chain tension, grab rear axle with fingers on both sides of gear, pull chain back so that chain is snug. While holding gear in this position, tighten one bolt on each side to hold axle in place, then tighten remainder of bolts. Rotate pedal to check operation and oil chain liberally while rotating.

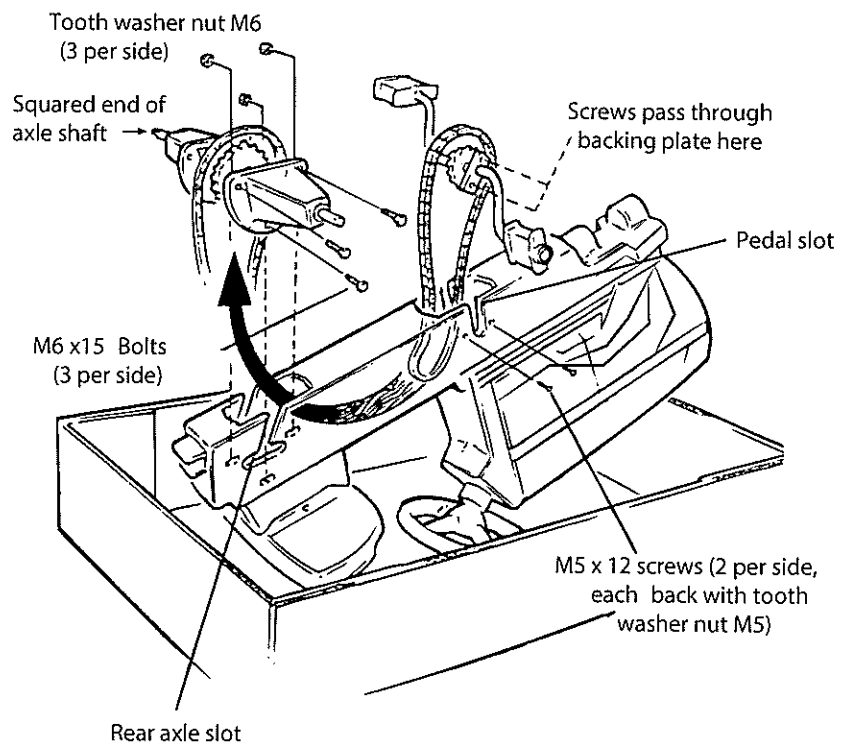

STEP 4

Assemble front axle. Slip the metal front axle support, with flat side up, (center groove should face down), over right axle hub pin as shown. Then press front axle hub pin through front axle as shown, (it does not matter which end of front axle you do first, as both ends are the same), and secure with a capnut using capnut driver and a hammer, (again, place it on a block of scrap wood first). Repeat for left side. Next, insert pin on left end of tie rod through hole in left axle hub arm as shown. Slip a $\varnothing 14$ OD x $\varnothing 4$ ID washer onto $\varnothing 4$ x 20 T/Screw and screw into pin on tie rod, as illustrated. Repeat for right side.

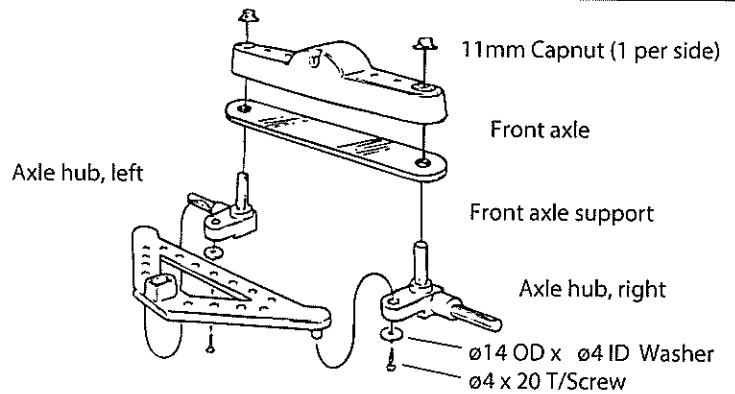

STEP 5

Assemble front wheels to front axle. Place a front wheel onto axle hub spindle; position a capnut onto end of axle hub spindle.

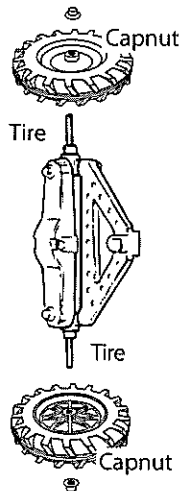

Carefully place front axle on edge of workbench (or a properly protected table) and pound capnut onto spindle as shown. It is critical to support axle hubs as shown for proper front wheel alignment. Repeat for opposite side.

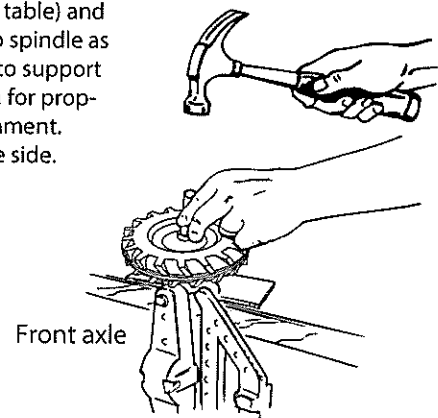

STEP 6

Position tractor close to one edge of carton lid. Find the rear wheel which has a slot for the axle on one side, and slide it onto the right axle as shown with the slot to the outside. Slide $\varnothing 24$ OD x $\varnothing 13$ ID washer onto axle. Insert cotter key through hole in one side of axle and use a pair of pliers to bend the prongs around axle. Pound hubcap into position using a block of wood and a hammer. Repeat for other side; make sure you keep the hubcap side of the wheel to the outside. Secure rear axle guard into opening in rear body with M4 x 6 screws. Repeat for pedal guard. Place assembled front axle in body as illustrated. With the tractor in a nose-down position, slide the front axle pin into place and secure with the M5 x 38 screw and square nut M5. Inset steering pin through tie rod as shown making sure pins are facing up. Drive a capnut onto steering pin. Flip the pedal tractor over and apply decals per directions on the sheet. Your ERTL pedal tractor is finished and ready for years of unending play!

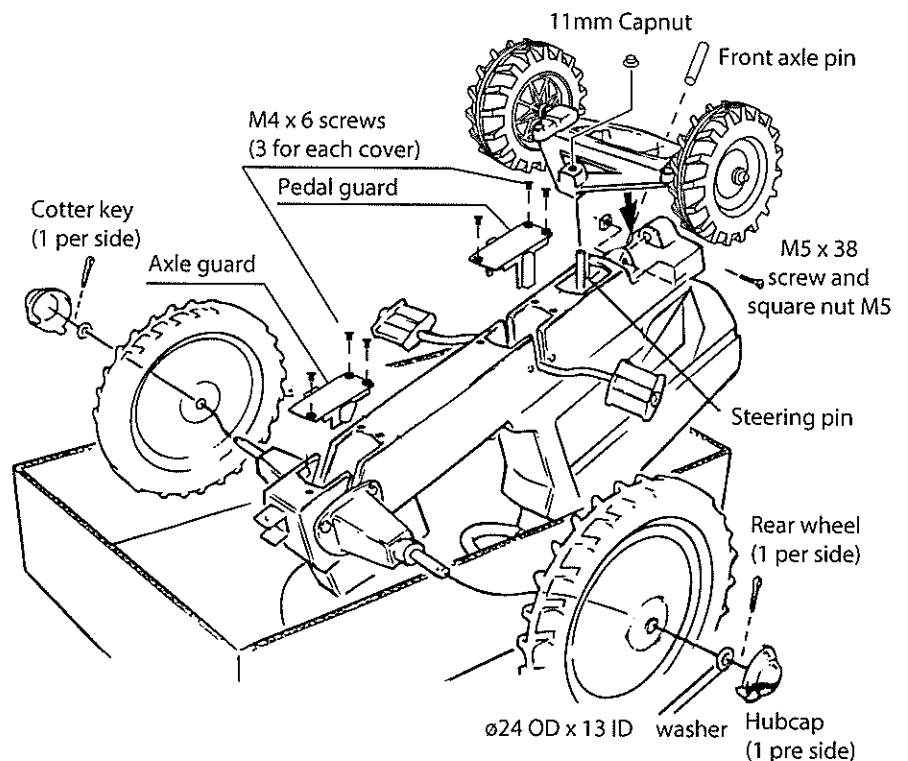

PARTS LIST

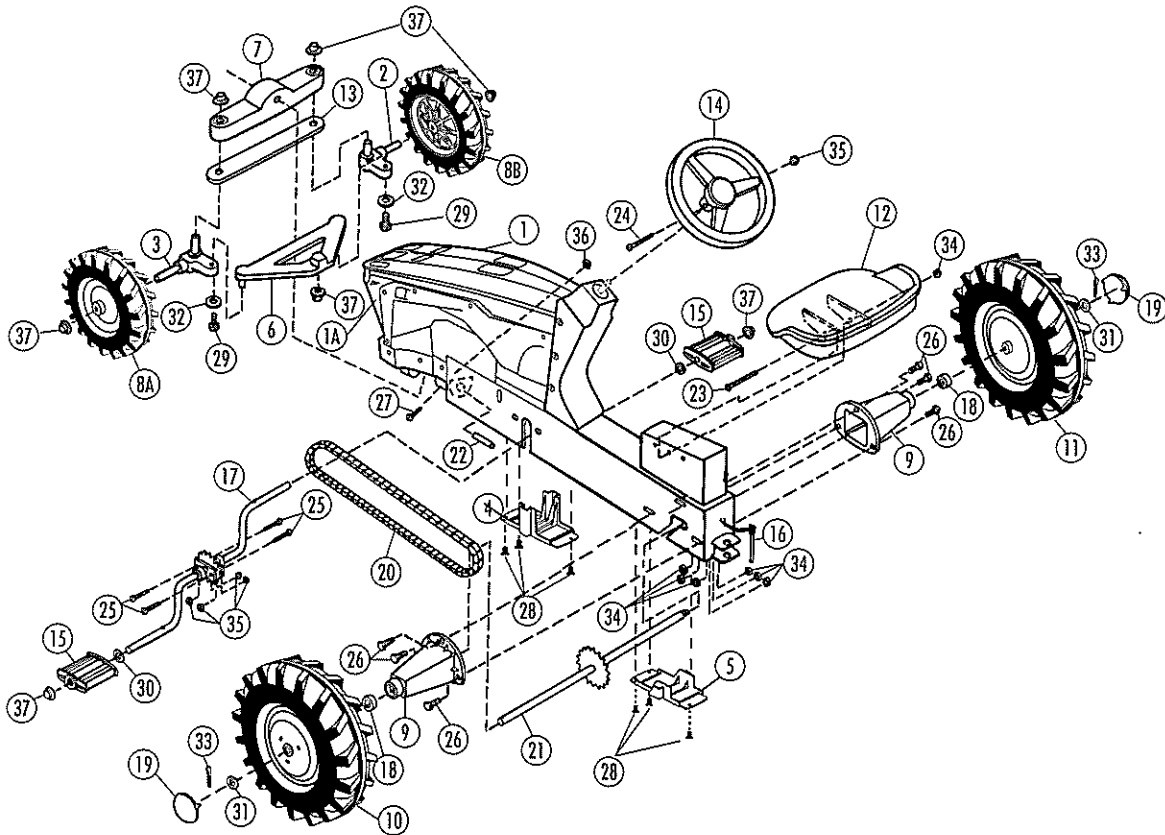

Ref. No.	Description	John Deere Part No.
1	Body	Not Available
1A	Grille	
2	Right Axle Hub	P10340
3	Left Axle Hub	
4	Pedal Guard	P10333
5	Axle Guard	
6	Tie Rod	P10055
7	Front Axle	P10052
8A	Left Front Wheel	P10174
8B	Right Front Wheel	P10175
9	Rear Axle Hub	P10050
10	2.75" Rear Idle Wheel - Wide	P10083
11	2.75" Rear Drive Wheel - Wide	P10084
12	Seat - Grey	P10651
	Decal Sheet	P10645

COMMON PARTS

Ref. No.	Description	Part No.
----------	-------------	----------

13	Front Axle Support	P10047
14	Steering Wheel	P10030
15	Pedal	P10080
16	Hitch Pin Assembly M3 x 10 Screw	P10017
17	Pedal Crank Arm-steel body	P10335
18	Bushing	P10032
19	Hubcap	P10001
20	Chain-Steel body	P10330
21	Rear axle/sprocket	P10085

HARDWARE

Ref. No.	Description
----------	-------------

22	Front Axle Pin 83 mm
23	M5 x 75 Screw
24	M5 x 31 Screw
25	M5 x 12 Screw
26	M6 x 15 Bolt
27	M5 x 38 Screw
28	M4 x 6 Screw
29	ø4 x 20 T/Screw
30	ø19 OD x ø11.8 ID Washer
31	ø24 OD x ø13 ID Washer
32	ø14 OD x ø4 ID Washer
33	Cotter Key
34	Tooth Washer Nut M6
35	Tooth Washer Nut M5
36	Square Nut M5
37	Capnut 11 mm

P10336



© TOMY
Oak Brook, Illinois 60523, USA
All Rights Reserved. Made in China.

This item carries a 1 year warranty.
To purchase replacement parts, please visit our website at www.tomy.com.
For replacement parts within our 1 year limited warranty, please call 1-800-704-8697

Please retain this instruction sheet for future reference.
099-45720 Rev.0

*Bagged Sets